

A CONCEPT FOR USING RECYCLED RUBBER GRANULES IN NOISE REDUCTION CONCRETE'S PANELS

R.G. ȚARAN¹ M. BUDESCU¹ D. COVATARIU¹

Abstract: *In traffic areas, from the outskirts of residences, systems for noise attenuation (induced by auto vehicles and trains) are necessary. Because these panels serve mostly the urban environment, its must have aesthetic aspect but in the same time must have to be easy to mount and to auto sustain themselves. Replacing the natural aggregates with recycled rubber granules it result a rubberized plain concrete used mostly in non-structural constructions. Reuse of rubber from used tyres can help prevent environmental pollution and, at the same time, contribute to building developments with lower costs. The concrete with recycled rubber has an energy absorption capacity proportionally increased. Deformation and energy absorption increases with the dimension of the rubber particle. This paper proposes manufacturing of new protective panels systems made only from concrete with recycled rubber particles.*

Key words: sound absorbent panels, recycled rubber, panels from concrete with recycled rubber.

1. Introduction

In general the construction materials have low absorbent capacity. The curtains and other textiles, furniture even people have a contribution at the total quantity of absorption. Together they form the natural absorption, which is not enough. This manner it shows up the need to use special conceived performant absorbents.

The perceived sounds are made from two components:

- 1) the direct sound – the sound that propagates directly towards the ear from the origin point;
- 2) the indirect sound – the sound that arrives to the ear after it was reflected once or many times by certain surfaces.

When the sound collides on the surface of a material, a part of its energy is absorbed, a part is transmitted and the rest is reflected back. The surfaces with common tough finishes, like dry plaster, wet plaster, concrete and glass absorbs very little sound. Sound-absorbent materials are designed such that it absorbs a percentage of the incidence energy of the sound. Therefore, the function of a sound-absorbent material is to reduce the reflected sound, and the degree we want this depends, mainly, on the area.

• Absorption mechanisms

The noise absorption represents the transformation of the kinetic energy of the

¹ Faculty of Civil Engineering and Building Services, "Gheorghe Asachi" Technical University of Iași

sound waves in thermic energy. A small part from a sound wave with high frequency is absorbed by the air.

The natural absorption is not enough to create an acoustic confort imposed by the norms. There are two manners to absorb the sound waves: Porous absorption and resonance.

1.1. The importance of materials for insulation

When it is considered to adopt a solution for insulation, the choosing of the materials for insulation to be used has a very important role. Previously, it is necessary an evaluation of the noise generating source and, taking into account the results, it must be chosen those materials with the acoustic and technical properties which satisfy the insulation requirements for the source. Depending on the requirements, the insulation and sound-absorbing materials can be used as such but they can be used also as components for sandwich panels, panels that can be jointed to realise the noise barriers.

Soundproofing panels from the sound barrier structure are designed according to the characteristics of the noise sources and the characteristics of location of area, the traffic being an important element that must be considered when design a sound barrier.

Equally important as the insulation materials are the fixture. For the best results it is proper that at the assembling of

some soundproofing walls or of a floating floor, to use special vibration proof systems for each type of structure.

It is ideal that when the insulation materials are chosen, besides the acoustic performances, to give importance also to the following aspects:



- the durability of the material/of the panel in time;
- impact strength;
- maintenance needs;
- fireproof properties;
- aggressive meteorological factors proof;
- mounting means.



Due to these multiple properties, to the importance and according to the destination area, the material gets different aspects. It has performing different functions, has the capacity to reflect the light, are resistant against fire propagation, is durable and easy maintenance.

Therefore, today there is a big range of sound-absorbent materials and structures, with multiple shapes, adequate to different requirements from an architectural project for zones with the most various destinations.

2. Acoustic and Soundabsorbing Panels

Acoustic and sound-absorbing panels can be mounted on the side of the roads, highways or railroads, near factories with noisy productive activity or in industrial areas.

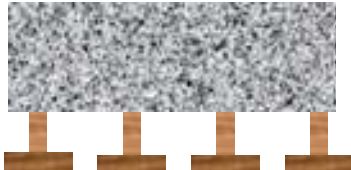
<p>Acoustic materials: Fibres (absorb high frequencies)</p>	
<p>Panels (absorb average frequencies)</p>	

Resonators (absorb adjustable frequencies)	
Smooth surface (reflect sounds)	

Sound-absorbing panels, besides insulation, have high impact strength (extremely important in case of access routes delimitation for roads and railroads), no maintenance required and does not permit fire propagation (having fireproof properties), can be positioned on bridges and walkways.

Also, the construction of some underground or aboveground passages in cities and highways constructions makes it necessary to use some sound-absorbing panels to protect the population.

2.1. Shape optimization of acoustic barriers

The conducted researches from all over the world led to the identification of numerous shapes of barriers that are much better than the usual barriers, made from a single panel with small thickness, flat and reflective. Due to the shape improvement, on a height of 2 m, it can be obtained a noise reduction, caused by the traffic, between 1.5 – 3.5 dB. We distinguish two different types of panels:

- acoustic barriers with a single reflecting edge of different shapes;
- acoustic barriers with multiple reflecting edges.

From acoustic barriers with a single reflecting edge we can remember the T or Y shape barriers, barriers with arrow-shape profile, feather, etc. In all these cases, the height of barrier and the type of the terrain on which they are placed must to be considered for the efficiency of the barriers. Also between the strong reflecting barriers, the ones with vertical faces offers better performances than the ones with slightly inclined sides.

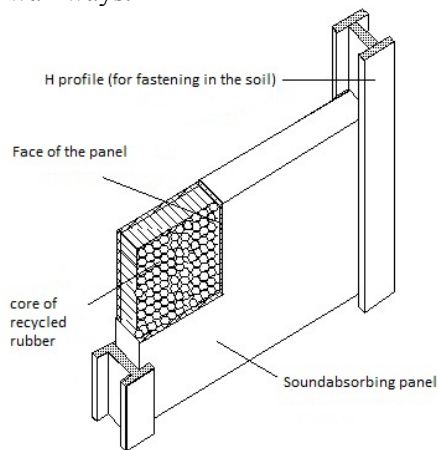

Fig. 1. Model of a sound absorbent panel

Sound absorbing panels from concrete with rubber are highly resistant to extreme atmospheric conditions, both at very low temperatures, and very high temperatures, without damages.

At the moment there are a lot of areas affected by the noise pollution. Urban zones crossed by railways, areas close by depots have to be soundproofed, because the moving trains, especially at the passing over the switches, generate a very high noise pollution.

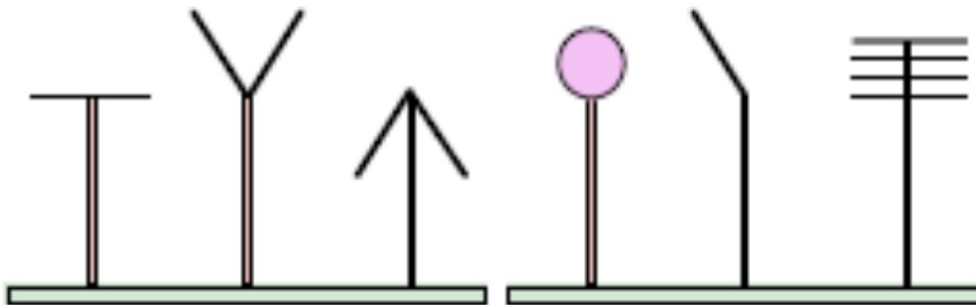

Fig. 2. Models of enhanced acoustic barriers

T profile barriers provides a substantially improvement to the insertion loss coefficient compared to the plane reflective barriers. Nevertheless, a barrier with arrow-shape profile has a bigger

silencing coefficient than the T profile barriers. Also, in the case of acoustic barriers with feather shape it is noticed that this silencing coefficient varies according to the tilt angle of the feather shape profile span.

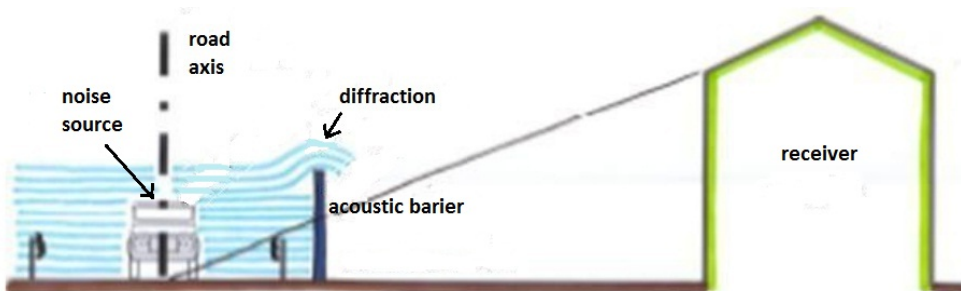

Fig. 3. The diffraction phenomenon of sound waves

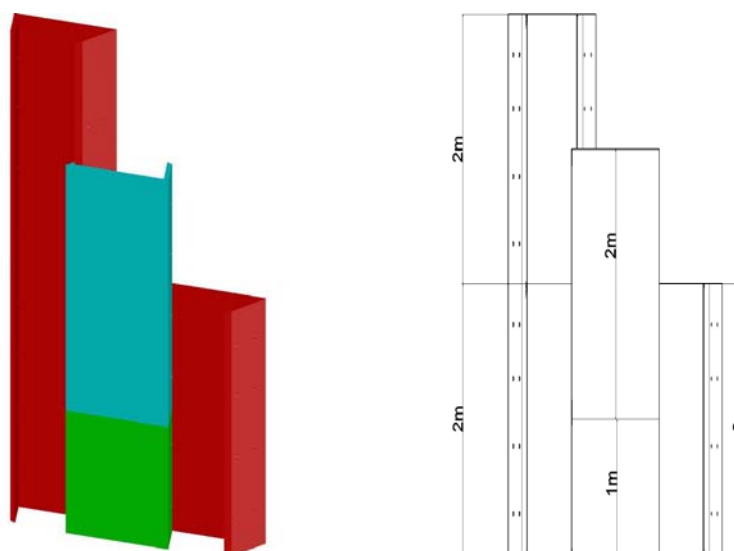

Fig. 4. Proposed models for acoustic barriers made from rubberized concrete



Fig. 5. Acoustic barrier panels existent type

3. Soundabsorbent Panels made from Concrete with Recycled Rubber

Rubber aggregates, provided from recycling and tyres soling, has granules of different dimensions or fibbers. Usually, the remaking is made mechanically at normal temperatures; there is another method, the remaking at very low temperatures. The remaking at normal temperatures is made by grinding the used tire or using granulation techniques. Processing at normal temperatures is done by used tires grinding or using granulation techniques.



Fig.6 Particles having different dimensions

3.1. Impact of using recycled rubber as partial replaced aggregate in concrete was well documented by compression tests, traction and bending

The maximum rubber aggregate quantity that can be replaced must be determined, although previews studies shown that in fresh state as well as in harden state, the ideal quantity of aggregate with the dimension under 4 mm has to be maxim 180 kg/m^3 (max 15%).

Rubber aggregate maximum quantity that can be replaced must be measured in such a way that the concrete have a homogeneous structure.

Maximum recycled rubber admixture from the concrete mix must not exceed 75 % so that the aggregate to be integrated into the mix.



Fig.7 Sound-absorbing panel from concrete with rubber particles

The deformation and energy absorbing capacity increased with the increasing of rubber sizes when the rubber contents remained constant (increasing the granule's dimensions tends to increase the energy's adsorption). It results that the impact energy of the rubber based concrete panels is bigger comparing to energy impact from plain concrete panels, fact that

leads to survival chances increases in case of a collision of a vehicle with the panel.



Fig.8 Detail of the concrete's structure with rubber particles

Main disadvantages as follows (shading, low light transmission, bad visibility of the drivers from streets, roads and highways) must be compared from the other aspects. The impact strength is also an extremely important characteristic, in case of a collision of a vehicle with the soundproofing wall, the panel being built

from concrete.

4. Final Remarks

Although the properties that are referring to strength and durability of the concrete with recycled rubber aggregates are not favourable, this one could present some advantages. These advantages are resulted from favourable attenuation characteristics, good thermal and sound insulation of the concrete. Rubber aggregates decrease the specific weight of the mix having a larger quantity of entrapped air that makes the pumping easier.

So much more, there must be underlines the eccologically advantages brought by the recycling of the used tires that, is well known, have a low degree of natural neutralisation.

Further studies are necessary, to establish the optimum quantity of rubber aggregates in concrete and to introduce it in the actual standards and procedures.

References

1. Feng Liu, Guixuan Chen, Lijuan Li, Yongchan Guo., Study of impact performance of rubber reinforced concrete, *Construction and Building Materials*, China, 2012.
2. Țaran Rareș-George, Studiu referitor la proprietățile stucturilor din beton armat utilizand cauciuc reciclat, *Creații universitare 2013*, vol. 6, 2013.
3. Topçu IB, Bilir T., Experimental investigation of some fresh and hardened properties of rubberized self-compacting concrete, *Mater Des* 2009;30(8):3056–65
4. <http://www.agir.ro/buletine/957.pdf>
5. <http://www.creeaza.com/tehnologie/electronica-electricitate/Realizarea-hartilor-de-zgomot515.php>