



## ENERGY OPTIMIZATION OF SMALL HOUSE PHOTOVOLTAIC PANEL BY INCREASING THE WORKING EFFICIENCY THROUGH ADDITIONAL MIRRORING OF SUN LIGHT ON THE PANEL AND RECOVERY OF THE HEATING ENERGY FROM THE PHOTOVOLTAIC CELLS

D. C. Ola<sup>1</sup>, D. M. Danila<sup>1</sup>, M. E. Manescu<sup>1</sup>

<sup>1</sup> University Transilvania from Brasov, Brasov, ROMANIA, danielola@unitbv.ro

**Abstract :** Solar energy is considered a huge source of renewable energy and is regarded as one of the future solutions to the ever growing demand for energy. The industrial production of photovoltaic panels has recently increased hugely for households use. Solar cells efficiency vary under temperature conditions with direct impact on the power output. The paper presents a photovoltaic panel system designed to maintain a balanced working temperature of the solar cells and in the same time increase efficiency by over exposing the solar cells to mirror reflected solar radiation to increase the efficiency during cloudy solar diffuse light.

**Keywords :** photovoltaic panels, mirror, heat pump, microcontroller.

### 1. INTRODUCTION

Since the price of the fossil fuel has escalated in the recent years so much, alternatives for independence towards the use of fossil fuels are being searched and investigated lately. The use of renewable energy sources of energy is the fore front in achieving this goal and solar energy is seen as the main energy source. The solar radiation can be converted through photovoltaic panel into power and this solution has been implemented in households that seek ways to reduce their energy costs.

A solar cell panel is basically a p-n semiconductor junction that when is exposed to light produces a dc current. Photovoltaic panels offer several advantages such as: high reliability, low maintenance cost, no environmental pollution, and absence of noise. The equivalent circuit of the Photovoltaic cell is shown in Figure 1.

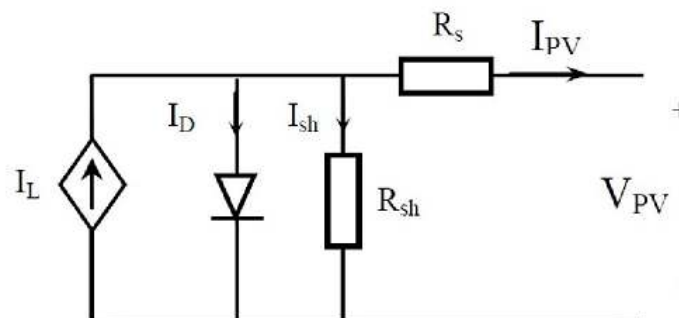

Figure 1: The schematic representation of an equivalent circuit for photovoltaic cell [2].

The mathematic model that describes the working functionality of the solar cells is presented in equation 1 and 2. These equations are used to plot the PV curves depending with the solar insolation and the temperature of the solar cell.

$$I_{PV} = I_l - I_0 \left( e^{\frac{q(V_{PV} + I_{PV}R_{SC})}{DKT}} - 1 \right) - \frac{V_{PV} + I_{PV}R_{SC}}{R_p} \quad (1)$$

$$P_{PV} = V_{PV} \times I_{PV} \quad (2)$$

where:  $I_{PV}$  is the photovoltaic current (A),  $I_l$  represents the current generated by the light (A),  $I_0$  is the diode saturation current,  $q$  is the charge of electron (coulomb),  $D$  is the diode factor,  $K$  is the Boltzmann's constant,  $T$  is the temperature of the solar cell (K),  $R_{sc}$  is the solar cell series resistance (ohm),  $R_p$  is the solar cell parallel resistance (ohm),  $V_{PV}$  is the module output voltage (V), and  $P_{PV}$  is the extracted photovoltaic power (W) [1].

The effect of temperature on solar cells is one of the major influences in the power output of the solar panels so that the voltage is inversely dependent on the temperature raise over the optimum level of temperature. The decrease in efficiency is higher with the increase of the temperature of the photovoltaic cells over the optimum temperature.

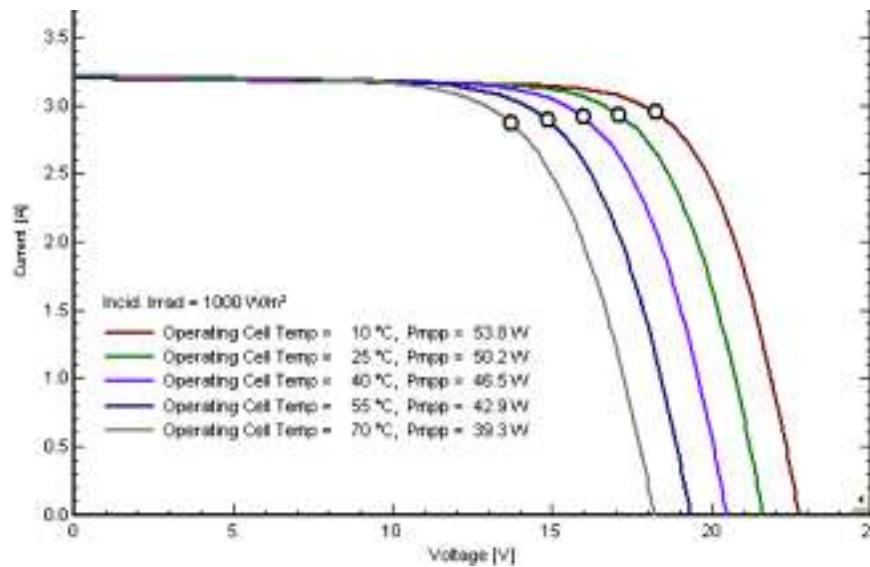

**Figure 2:** Output characteristics of a photovoltaic module for different temperatures [2].

In Figure 2 it is shown the effect of temperature on a photovoltaic panel I-V characteristic when exposed at constant radiation. It is well seen that for lower temperatures the voltage increases while at higher temperatures there is significant decrease [3].

The drop in energy production efficiency of photovoltaic solar panels is dependent on working temperatures of the panel, such that a drop of 1% of the peak output is considered for every increase in the temperature of the photovoltaic solar panel over the optimum 42°C. The experiments conducted by Rivers State University of Science and Technology at Port Harcourt, Nigeria found similar results for operating panel temperatures over 44°C [5].

## 2. THE EXPERIMENTAL STAND AND RESEARCH METHODS

By utilization of state of the art microcontroller technology for the automation [4] of the monitoring and regulation of the heat exchanger, it is possible to optimize the working temperature of the photovoltaic cells so that the electricity output of the panel will be optimized during the critical exploitation periods (ex.: high sun radiation or cold freezing winters) and in the same time gaining the excess heating energy to be used in other applications that exploit this energy source.

The experimental stand will use the mirror system to shine upon the photovoltaic solar panel to provide higher sun radiation intensity. The panel is also fitted with a heating exchange element that will maintain the photovoltaic cells at an optimum working temperature.

The working conditions will be those of lower sun light found in cloudy days as well as during the early hours of mornings and late hours of the sun set.

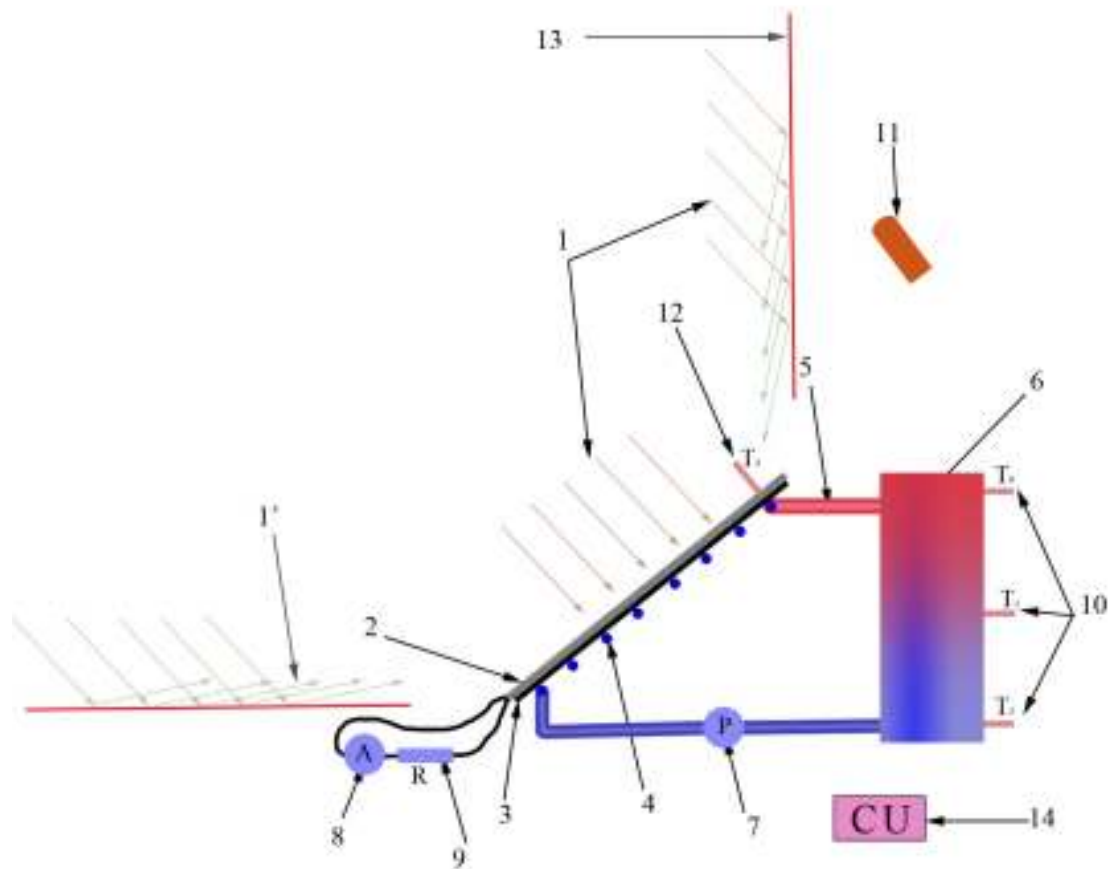

**Figure 3:** The schematics of the working principles.

1 – direct sun light; 1' – reflected sun light; 2 – photovoltaic cells; 3 – support plate for the photovoltaic cells; 4 – heat exchanger coil; 5 - return pipe hot water; 6 – water tank; 7 – coolant circulation pump; 8 – ampere meter; 9 – electric power resistive load; 10 – thermal sensors of the water tank; 11 – lux meter sensor measuring the light intensity; 12 – photovoltaic cells thermal probe; 13 – mirrors; 14 – control unit.

In Figure 3, the solar radiation (1) shines on the photovoltaic panel surface (2). In addition the mirrors (13) will reflect more light on the panel through the reflected radiation (1'). On the rear side of the photovoltaic cells (2) it is applied a heat sink sheet metal material (3) that is foreseen with proper insulation so that the functioning of the photovoltaic cells will not be hindered. On the other side of the element (3) it is welded a coil pipe (4) that will be used to extract the heat from the cells. The cooling coil (4) is connected to the circuit (5) made up from a storage tank (6) and a recirculating pump (7). The experimental stand will monitor the following three parameters: the electric current generated by the photovoltaic panel (2) by using a voltage sensor (9), the panel temperature  $T_3$  (12), the water temperature from the storage tank (10) on three locations ( $T_0$ ,  $T_1$ ,  $T_2$ ) and the intensity of the sun radiation by using the sensor (11).

The control unit (14) will run the automation program that will be responsible to the monitoring of the parameters and the positioning of the mirrors so that the panel will be exposed to more light and in the same time the cooling system will ensure an optimum working condition.

The experimental stand will be used in natural conditions so that the cooling system will maintain the photovoltaic panels at a temperature of  $40^{\circ}\text{C}$  during the over exposure to the sun radiation. The monitoring of the heating recovery will be also analyzed.

The results of the tests will provide a characteristic graph of the photovoltaic panel according with the efficiency of the output current when using the mirrors during diffuse light.

The experimental test will be done in natural conditions in order to cover the most representative conditions of diffuse light or lower sun radiation during the sun rise and sun set.

### 3. CONCLUSIONS AND EXPECTED RESULTS

Considering that the efficiency of the photovoltaic panels is directly dependent on the working temperature, the present paper aims to present an optimization to the photovoltaic panel by additional reflected sun light by a system of mirrors. The control of the operating temperature of the photovoltaic cells is made through a cooling system that will extract the heating energy and will make it available in household applications.

The advantage of adding more sun light radiation to the panel is beneficial especially on cloudy days and in the early morning and evening hours when the amount of sun radiation is lower. The photovoltaic panels are not foreseen with most of the time when high sun radiation is available during summer the output of the home solar panels will not provide the optimum output expected according with potential of the solar radiation.

The proposed system tries to exploit this disadvantage and harvest the potential heat energy through a heat exchanger in order to provide house hold running water (remote touristic resorts, poor access to other sources of energy etc.) or other sources of renewable energy production systems (steam micro-turbines, heat pumps etc.).

The experimental results will show the potential to optimize the energy efficiency of solar cells in periods of low output and in the same time to harness the heating energy that is directly linked with this panel.

The data collected will be used in designing a new type of house solar panel that could provide extra efficiency especially for remote locations where agro-tourism makes an impact upon the resources of the place.

### REFERENCES

- [1] Azab M., Optimal power point tracking for stand-alone PV System using particle swarm optimization, IEEE Int Symposium on, in Industrial Electronics (ISIE), 2010, pp. 969-973.
- [2] Jafari Fesharaki V. et al., The Effect of Temperature on Photovoltaic Cell Efficiency, Proceedings of the 1st International Conference on Emerging Trends in Energy Conservation -ETEC, Tehran, Iran, 20-21 November 2011.
- [3] Patel H. et al., Maximum Power Point Tracking Scheme for PV Systems Operating Under Partially Shaded Conditions, IEEE Transactions on Industrial Electronics, Vol. 55, No. 4, pp. 1689-1698, 2008.
- [4] Thierheimer W., The theory of technical systems of agriculture and food industry, Transilvania University of Brasov Publishing House, ISBN 973-8124-76-X, 2001, pp. 30-33.
- [5] <http://greenliving.nationalgeographic.com/effects-temperature-solar-panel-power-production-20500.html>.