

# INTERNATIONAL SCIENTIFIC CONFERENCE

CIBv 2010

12 – 13 November 2010, Braşov

## STEEL JOINTS BEHAVIOUR EVALUATION

Dorin RADU\*, Atanasie TALPOŞI\*

\* Transilvania University of Brasov – Faculty of Civil Engineering

Corresponding author: Dorin RADU, E-mail: dorin.radu@indomo.ro

Abstract: When is referred to the swivel joint stiffness, stiffness designation means that between the combined elements (ex: beam - column) there is no relative rotation, regardless of the external loads level. A pin-ended joint can be considered when connected elements can rotate freely. In terms of joint strength, it is considered complete strength when the resistance is stronger than the weakest element of the connected elements, while partial resistance joints are weaker than the combined elements. These partial strength joints are calculated to convey the internal forces and not to resist the entire load bearing elements combined. A pin-ended joint does not transmit any bending moment. Considering the strength and stiffness properties of joints, lead to their three modeling: articulated, rigid, semi-rigid.

*Key words:* Joints, Semi-rigid, Joints Ductility.

### 1. PRESENTATION OF PROBLEM

As long as the swivel joint stiffness is considered in the calculation, the joints can be made in semi-rigid version, ie no rigid or articulated. Thus, new modeling capabilities: semi-rigid / total resistance, semi-rigid / partial resistance.

SR EN 1993 standard is considering these possibilities by introducing three modeling: simple (if pin-end), semi-continuous and continuous (Table 1)

Table 1: Type of joint model

Method of global analysis	Classification of joint		
Elastic	Nominally pinned	Rigid	Semi-rigid
Rigid-Plastic	Nominally pinned	Full-strength	Partial-strength
Elastic-Plastic	Nominally pinned	Rigid and full-strength	Semi-rigid and partial-strength Semi-rigid and total-strength Rigid and partial-strength
Type of joint model	Simple	Continuous	Semi-continuous

Terms of continuous, semi-continuous and nominally pinned are defined as follows:

- Continuous: the joint ensures a perfect rotation continuity between connected elements;
- Semi-continuous: the joint ensures a partly rotation continuity between connected elements;
- Simple: the joint interrupts the rotational continuity between connected elements.

Table 2: Joints modelling (SR EN 1993-1-8-2006)

Rigidity	Resistance		
	Full strength	Partial strength	Pinned
Rigid	Continuous	Semi-continuous	-
Semi-rigid	Semi-continuous	Semi-continuous	-
Pinned	-	-	Simple

Interpretation of these types of modeling should be done in accordance with the structural analysis type. In the case of a global elastic analysis, only the stiffness properties of joints are important for joints modeling. The semi-rigid connection is taken into account in the calculation model by means of a spring which is characterized by the elastic constant  $k$ .

When performing a rigid-plastic analysis, the main feature is the joint resistance. In all other types of analysis are important properties such as stiffness and the resistance. In Table 2. [5] joints are presented for each type of modeling analysis.

In current cases of analysis of a structure is not practical separation of the joint deformability from the web panel of the column. Therefore, these deformations can be modeled by a single spring at the intersection of joint elements axes - modeling deformation behavior of a node takes into account the deformation of the panel from shear deformation of the web and rotation of the connections.

Nodes configuration should be design to resist to  $M_{b1,Ed}$  and  $M_{b2,Ed}$  bending moments,  $N_{b1,Ed}$  and  $N_{b2,Ed}$  axial forces,  $V_{b1,Ed}$  and  $V_{b2,Ed}$  share forces transmitted from the connected elements to the joint (Figure 4.29).

The resulted share force  $V_{wp,Ed}$  from the web panel, will be:

$$V_{wp,Ed} = (M_{b1,Ed} - M_{b2,Ed})/z - (V_{c1,Ed} - V_{c2,Ed})/2 \quad (1)$$

where  $z$  is the lever arm.

In order to model a node so that it correctly reproduce the expected behaviour, the share web panel and each connection must be modelled separately, taking into account the bending moments and axial forces of each element which interfere at the edge of the web panel (Figure 2 and Figure 3).

As a simplified alternative to the presented above model, a unilateral node configuration can be modelled as a single node, and configuration of a double-side node can be modelled as two separate nodes which interact with each other. Therefore, configuring a beam to column double-side node has two moment-rotation characteristics, one for the right side of the joint and the other for the left. In a bilateral beam to column node, each fixture is modelled with separate rotation points (Figure 3), each end of the beam has a moment-rotation feature that takes into account the behaviour of the shear web panel and the influence of the correct connection.

When determining the moment resistance and rotation stiffness for each node, the possible shear web panel influence will be taken into account according with  $\beta_1$  and  $\beta_2$  coefficients, where  $\beta_1$  is the value of the transformation parameter  $\beta$  for the right side of the node and  $\beta_2$  is the value of the transformation parameter  $\beta$  for the left side of the node.

Table 3 present approximate values of the transformation parameter  $\beta$ . The exact values of  $\beta_1$  and  $\beta_2$ , based on the values of beam bending moments  $M_{j,b1,Ed}$  and  $M_{j,b2,Ed}$ , from the intersection of the elements centres of gravity lines, can be determined using the simplified model shown in Figure 1 (b) as follows:

$$\beta_1 = \left| 1 - M_{j,b2,Ed} / M_{j,b1,Ed} \right| \leq 2, \quad \beta_2 = \left| 1 - M_{j,b1,Ed} / M_{j,b2,Ed} \right| \leq 2 \quad (2)$$

where:  $M_{j,b1,Ed}$  is the moment at the intersection from the right hand beam

$M_{j,b2,Ed}$  is the moment at the intersection from the left hand beam

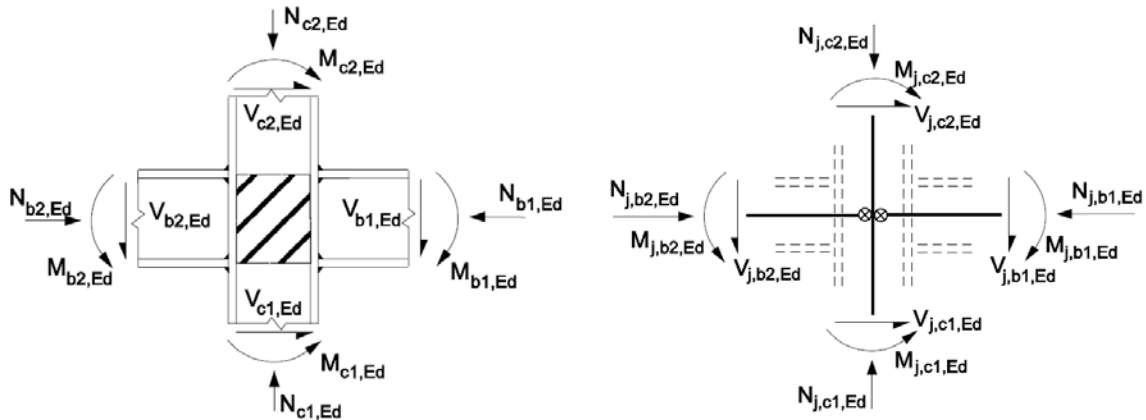

a) Values nearby the web panel    b) Values at the intersection of the elements centre lines  
 Fig. 1. Forces and moments acting on the joint

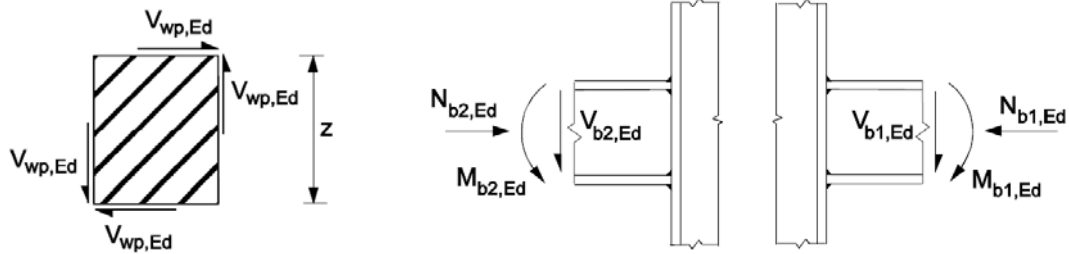
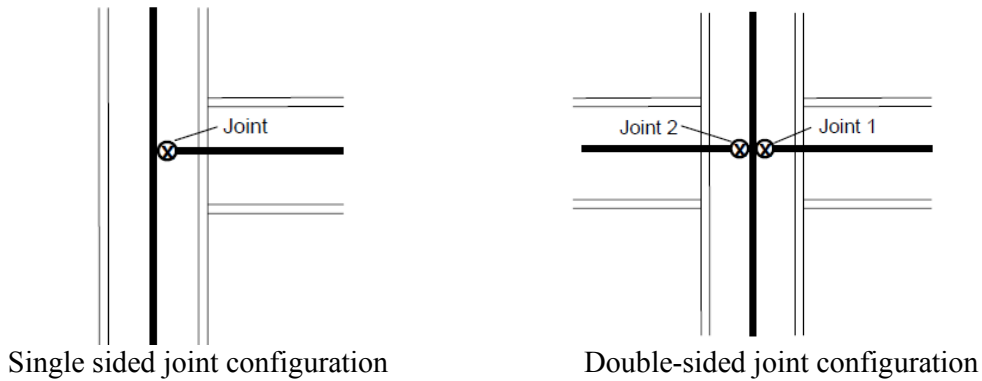

Fig. 2. Forces and moments acting on the web panel at the connections



Single sided joint configuration                      Double-sided joint configuration  
 Fig. 3. Modelling the joint (1 – Node; 2 – Left Node; 3 – Right Node)

The transformation parameter  $\beta$ , puts in direct connection the web panel shear with tension and compression forces from the joint. Spring characteristic curve  $M_b - \Phi$  which represents the joint behaviour is shown in Figure 5c; this results from summing the joint rotation ( $\Phi$ ) with web panel rotation ( $\gamma$ ).

In case of a single sided joint, the deformability characteristic curve from column web panel share and rotation can be transformed in a  $M_b - \gamma$  curve through  $\beta$  transformation parameter (Fig.5).

Fig. 4. Definition of the transformation parameter  $\beta$ 

Fig. 5. The bending characteristic of the spring

Since the values of the transformation parameter  $\beta$  can be achieved only after determining the internal efforts distribution, its accurate determination can be made only through a cycles calculation. But for practical applications, these iterative methods are difficult to use, so it is necessary to provide conservative values for  $\beta$ . These values vary between  $\beta = 0$ , (double sided joint, equal moments equal and opposite directions, Figure 6a) to  $\beta = 2$ , (double sided joint, equal moments equal and identical directions, Figure 6b).

Fig. 6. Factor  $\beta$  limits: a) equal and opposite direction moments; b) equal and same direction moments.

Nonlinear behaviour of the joints, represented by springs with a certain rotation stiffness, it is quite difficult to use in current design practice. Therefore, the actual moment-rotation characteristic curve of the joint can be modelled without a significant loss in accuracy by an elastic - perfectly

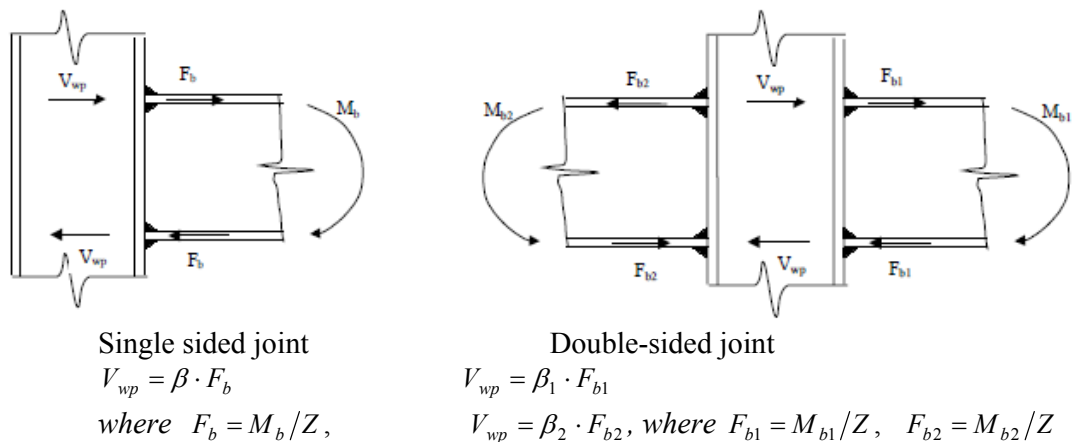
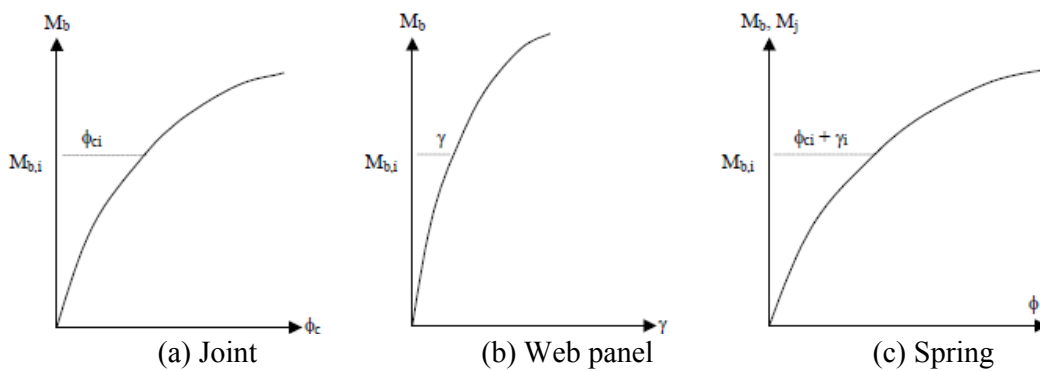
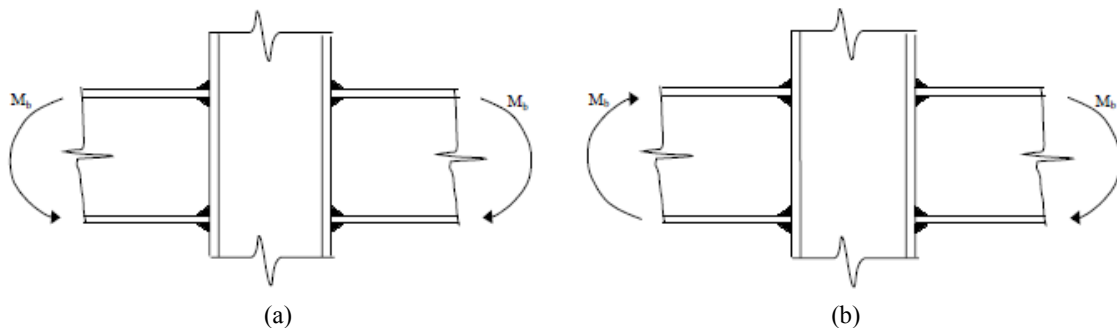
plastic characteristic curve (Figure 7a). This representation has the advantage of being similar to the behaviour characteristic curve of the bended elements. (Figure 7b).

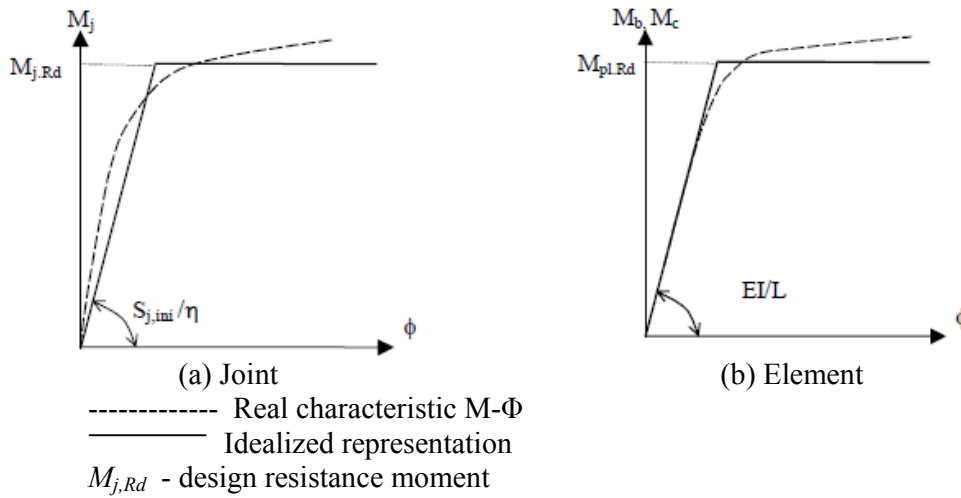
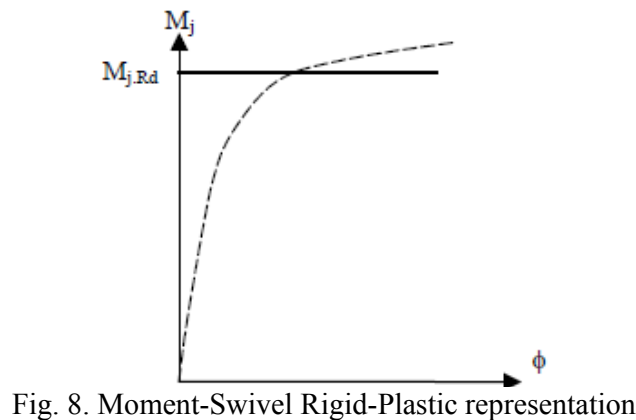
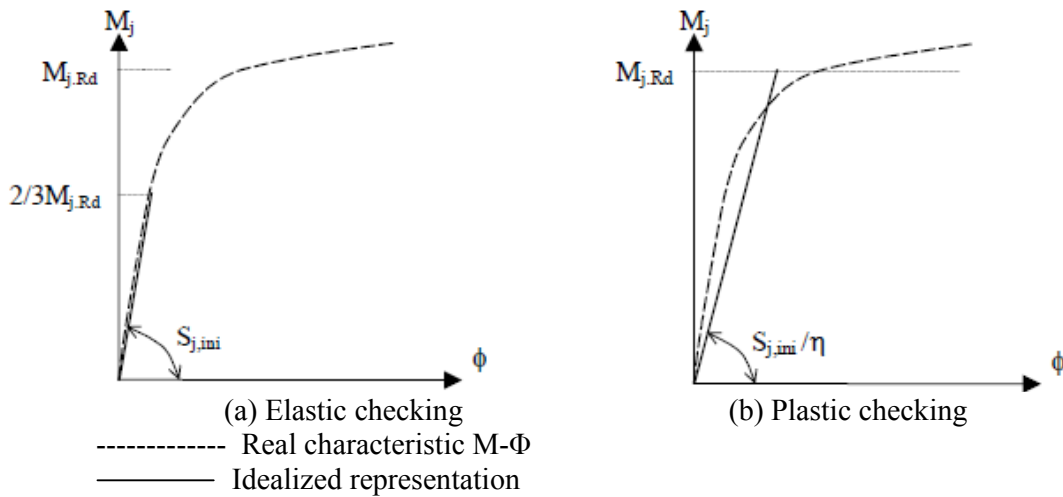
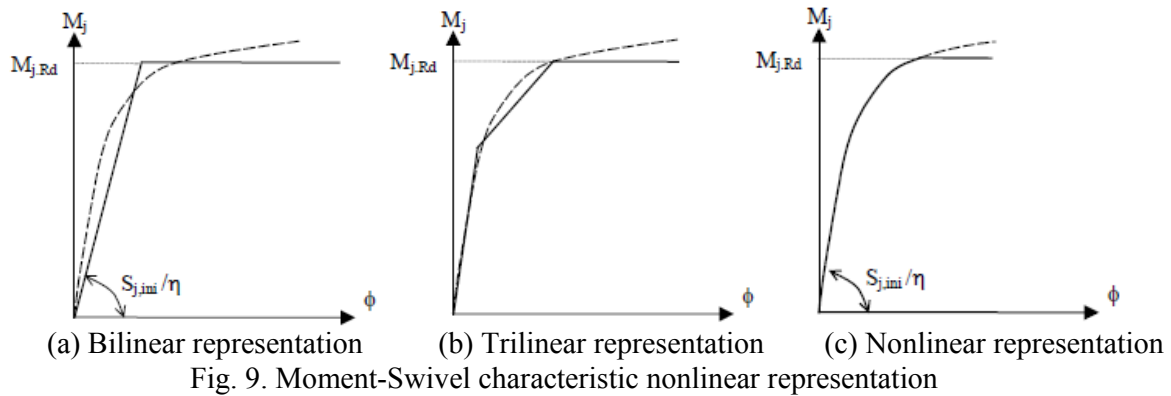

Fig. 7. Bilinear moment-rotation curves

There are neglected the effects of material cold straining. This explains the behaviour differences between the idealized behaviour of the joint and actual behaviour.

Depending on the type of analysis, can be choose different modes of idealization of the characteristic M –  $\Phi$ : elastic modelling for elastic analysis, rigid-plastic modelling for a rigid-plastic analysis (Fig. 8) and a nonlinear modelling for the elastic-plastic analysis (Fig. 9).





The characterization of the  $M-\Phi$  curve can be ascertained by experimental testing or mathematical models based on the geometrical and mechanical properties of the joint. Full-scale experimental tests are naturally the most reliable method of description of the rotational behaviour of structural joints. However, they are time consuming, expensive and cannot certainly be regarded as a design tool. In addition, the data gathered from tests of prototype joints are few and generally limited to displacement and surface measurements, as strain measurements, for instance. Therefore the results cannot be extended to different joint configurations. Nonetheless, tests [7], [8] provide accurate information on the joint response that is used to validate mathematical models of prediction of the  $M-\Phi$  curve. Mathematical models for representation of the curve include: (i) curve fitting to test results by regression analysis, (ii) simplified analytical models, (iii) mechanical models that take into account the various sources of joint deformability and (iv) numerical models.

Mechanical models are the most effective solution for an accurate description of the complex nature of bolted joint behaviour. These models use a set of rigid and flexible elements to simulate the overall joint.

Current design practice adopts the so-called component method for the prediction of the rotational behaviour of beam-to-column joints. For the purposes of simplicity, any joint can be subdivided into three different zones: tension, compression and shear. Within each zone, several sources of deformability can be identified, which are simple elemental parts (or “components”) that contribute to the overall response of the joint: (1) column web subjected to shear, (2) column web subjected to compression (3) column web subjected to tension (4) column end plate in bending, (5) beam end plate in bending (6) beam web tensioned or compressed; (7) tensioned bolts (8) tensioned weldings.

From a theoretical point of view, this methodology can be applied to any joint configuration and loading conditions provided that the basic components are properly characterized. Essentially, the method comprises three basic steps: (i) identification of the active components for a given structural joint, (ii) characterization of the individual component  $F-\Delta$  response and (iii) assembly of those elements into a mechanical model made up of extensional springs and rigid links. This spring assembly is treated as a structure, whose  $F-\Delta$  behaviour is used to generate the  $M-\Phi$  curve of the full joint.

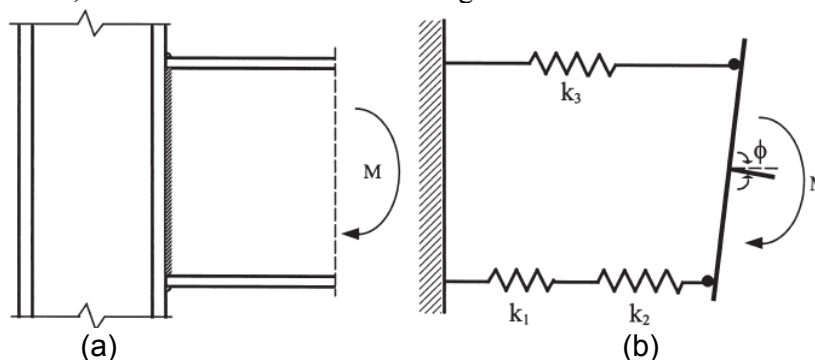

Fig. 10. Active components and mechanical model adopted by Eurocode 3 for characterization of the joint rotational stiffness – welded beam-column joint

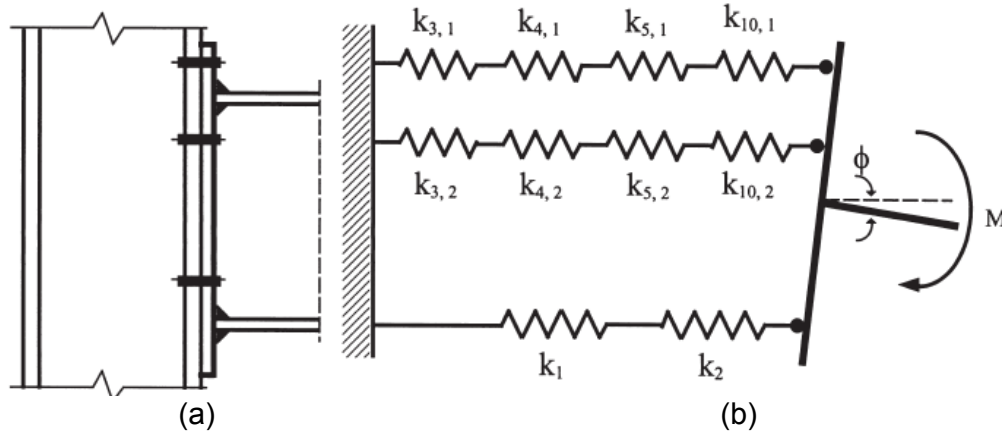
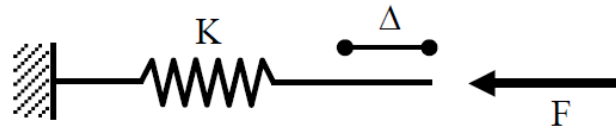
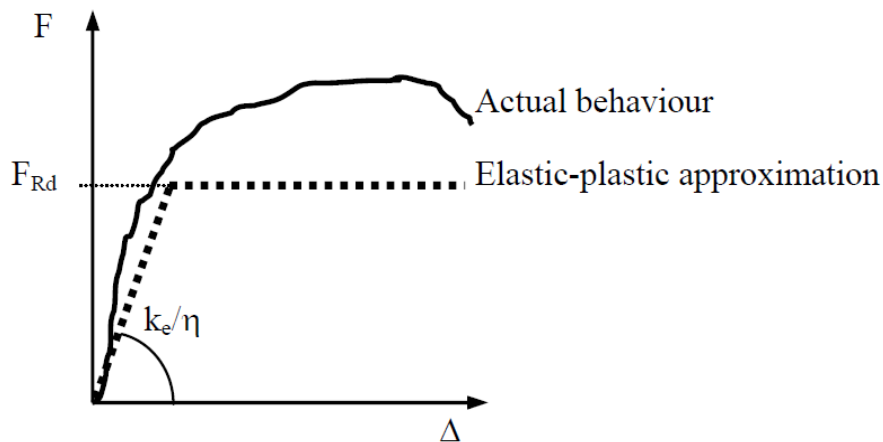

Fig. 11. Active components and mechanical model adopted by Eurocode 3 for characterization of the joint rotational stiffness – bolted beam-column joint

Within the framework of the component method, the basic joint components are modeled by means of nonlinear extensional springs (Fig. 11a;  $K$ : spring axial stiffness). This complex behaviour can be approximated with simple relationships without significant loss of accuracy. The elastic-perfectly plastic response is one of the simplest possible idealizations. Following the Eurocode 3 approach for idealization of the flexural joint spring nonlinear behaviour, this response is characterized by a secant stiffness,  $k_e/\eta$ , and a full plastic resistance,  $F_{Rd}$  (Fig. 11b).  $k_e$  is the initial stiffness of the component and  $\eta$  is a stiffness modification coefficient. Eurocode 3 defines this coefficient for different types of connections. For a single component, similar values can be adopted. The post-limit stiffness,  $k_{p-l}$  is taken as zero, which means that strain hardening and geometric nonlinear effects are neglected. Regarding the component ductility, i.e. the extension of the plastic plateau, the code [5] presents some qualitative principles that are however insufficient. For instance, the component column web in shear has very high ductility and therefore the deformation capacity is taken as infinite; on the other hand, the bolts in tension are brittle components with no plastic plateau.



(a) Extensional spring representing a generic component.



(b) Actual behaviour and elastic-plastic response.

Fig. 12. Modelling of a component subjected to compression

## 2. CONCLUSIONS

In the current design is necessary to adopt the use of a wide range of types of joints. The use of semi-rigid joints type, requires an assessment of ductility (rotation) in node and therefore an assessment of the entire nonlinear moment-swivel response of the joint.

The component method accepted by the standards for wide use in current practice does not provide the information necessary for more complex joints; more than that, it provides separate procedures to evaluate the initial strength and stiffness of steel and composite joints. These procedures set out in Eurocode 3 and Eurocode 4 regulations, are reproducing these properties in a satisfactory manner with the possibility of ease calculation.

Ductility evaluation presents two difficulties when compared with the initial strength and stiffness: knowledge of the nonlinear force - deformation response of each component and knowledge of the nonlinear moment-rotation response of the joint. The first problem is still insufficiently explored in the literature, most research is focused on assessing the strength and rigidity of structural components. The second problem requires numerical iterative procedure, because of plasticization and instability phenomena.

Assuming known the nonlinear behavior of components, it is necessary to determine the total nonlinear moment-rotation response of the joint type and consequently determination of resistance, initial stiffness and maximum rotation of the joint

## REFERENCES

1. DUBINA, D., STRATAN, A., *Behaviour of welded connections of moment resisting frames beam to column joints*, *Engineering Structures*, **Vol. 24**, No. 11, 1431-1440, 2002.
2. BALLIO, G., *ECCS Approach for the Design of Steel Structures against Earthquakes*, Symposium on Steel in Buildings, Luxembourg, 1985, IABSE-AICP-IVBH Report, **Vol.48**, pp. 373-380, 1985.
3. BART, A.S., BOWMAN, M.D., *Effect of local details on ductility of welded moment connections*, *Journal of Structural Engineering*, ASCE, **127**(10): 1145-1151, 2001.
4. Eurocode 3 Part 1.1 *Design of steel structures, General rules and rules for buildings*. CEN, European Committee for Standardization,
5. Eurocode 3 Part 1.8 *Design of joints of steel structures*. CEN, European Committee for Standardization
6. Eurocode 8 - *Design provisions for earthquake resistance of structures - Part 1-1: General rules - Seismic actions and general requirements for structures*, CEN, ENV 1998-1-1.
7. SIMOES DA SILVA, A. GIRAO COELHO, *A ductility model for steel connections*, *Journal of Constructional Steel Research* **57** (2001) 45-70
8. SIMOES DA SILVA, ANA GIRAO COELHO, *EVALUATION OF DUCTILITY IN STEEL AND COMPOSITE BEAM-TOCOLUMN JOINTS: ANALYTICAL EVALUATION*, *Journal of Constructional Steel Research* 2002

*Received October 30, 2010*